

INTRODUCTION

The M.K. Plastics series K-RD are manufactured to meet the needs of the odor control and corrosive HVAC industries by providing a corrosion-resistant FRP Damper that is used to regulate an exhaust flow or shut off and isolate a system. The operating conditions for the dampers are designed to match the operating conditions of the duct system. Premium vinyl ester resins are used throughout the damper. Fire-retardant resins are also available for a Class 1 flame spread.

M.K. PLASTICS PROVIDES FOUR DAMPER MODELS

- **Model K-RD-501:** Used to control airflow for balancing a system. Model K-RD-501 is less expensive and has a shaft seal, but does not have a blade seal.
- **Model K-RD-502:** Used to control airflow for balancing a system. Model K-RD-502 has a shaft seal and full circumferential blade stop.
- **Model K-RD-503:** Used for isolating a system with low leakage. Model K-RD-503 has a shaft seal, blade seal, and a full circumferential blade stop. Designed for up to 30.0" w.g.
- **Model K-RD-504:** Used for isolating a system, and has a PTFE encapsulated O-ring to provide a factory-tested watertight seal. Each model 504 damper is tested watertight before shipping.

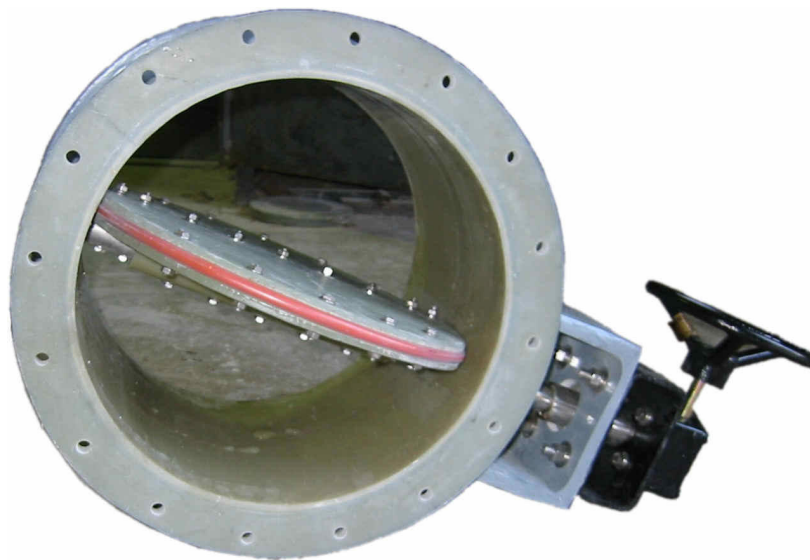

K-RD SUGGESTED SPECIFICATION

Furnish and install at locations shown on plans, round FRP single-blade fiberglass dampers. Damper frame shall be of one piece construction with a resin rich interior corrosion barrier minimum of 100 mills. A structural lay-up shall consist of alternate layers of chopped strand mat and woven roving to conform to ASME/ANSI ATP-1 and ASTM D3982. The glass to resin ratio shall be a minimum of 35% glass to 65% resin. Wall thickness, flange thickness, drilling pattern and width shall conform to ASTM D3982 Table 1. Exterior surface of the damper shall contain UV inhibitors and a gelcoat, standard color shall be M.K. Plastics Light Gray. The damper blade shall be constructed of the same material as the damper frame and shall have a resin rich surfacing veil on both sides. Blade stiffeners shall be FRP or FRP encapsulated as required for stiffness. The axles shall be 304 or 316 stainless steel or pultruded FRP as required to meet corrosion resistance requirements. Leakage shall not exceed 3 cfm per square foot at 12" w.g. or 5.25 cfm per square foot at 30" w.g. as required in this specification for isolation. Damper shall be provided with stainless steel hand locking quadrant, gear operators, chain wheel operators, or other actuation devices as required in this specification.

All interior metal shall be 304 or 316 stainless steel. Gaskets shall be EPDM. Other gasket materials shall be available upon request. All FRP fabrication shall meet or exceed quality requirements of ASTM D 3982 and ASME/ANSI ATP-1. Damper shall be M.K. Plastics Models K-RD-501, K-RD-502, K-RD-503 or K-RD-504.

MODEL K-RD-501

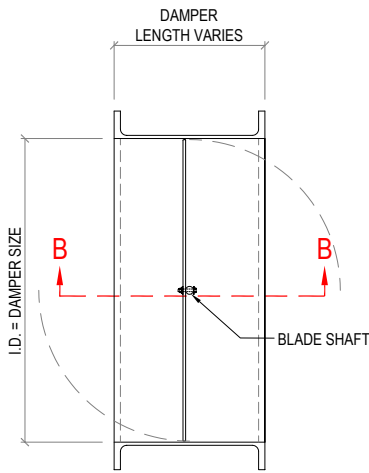

SECTION A

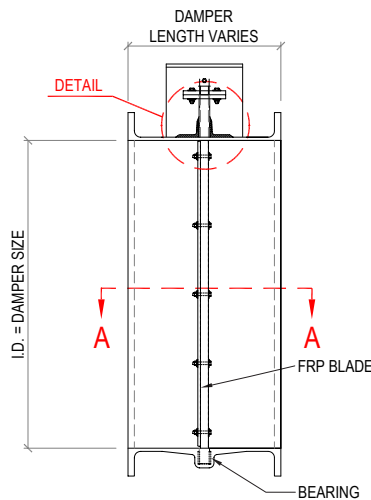

SECTION B

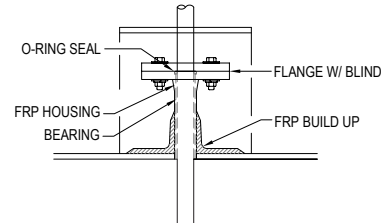

DETAIL

MODEL 501 HAS A SHAFT SEAL, BUT DOES NOT HAVE A BLADE STOP OR BLADE SEAL. MODEL 501 IS USED TO BALANCE A SYSTEM

MODEL K-RD-502

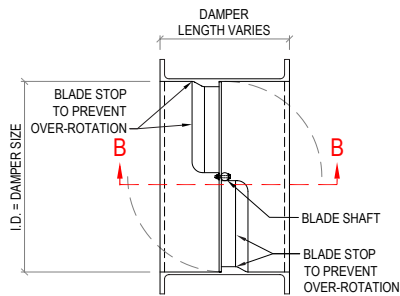

SECTION A

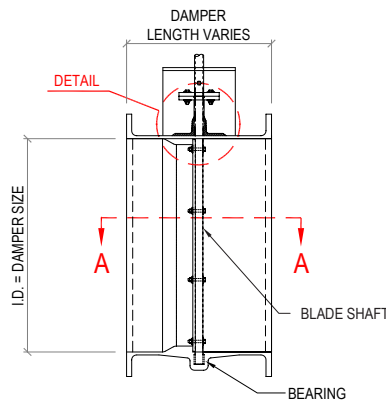

SECTION B

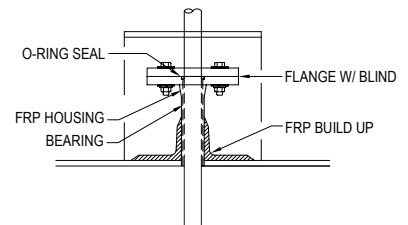

DETAIL

MODEL 502 HAS A SHAFT SEAL AND FULL CIRCUMFERENTIAL BLADE STOP. MODEL 502 DOES NOT HAVE A BLADE SEAL. DESIGNED TO WITHSTAND UP TO 30" W.G.

MODEL K-RD-503

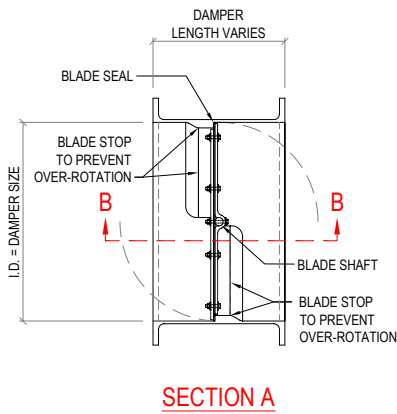

SECTION A

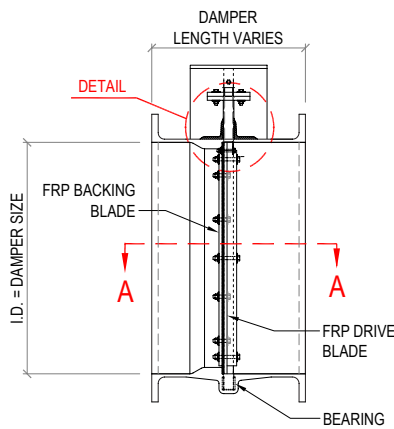

SECTION B

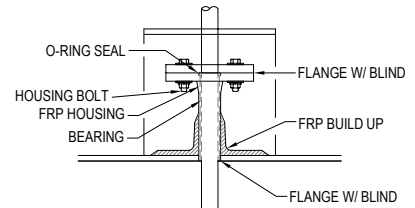

DETAIL

MODEL 503 HAS A SHAFT SEAL, BLADE SEAL AND FULL CIRCUMFERENTIAL BLADE STOP. MODEL 503 IS DESIGNED TO PROVIDE ISOLATION WITH A LOW LEAKAGE RATE TO 30" W.G.

MODEL K-RD-504

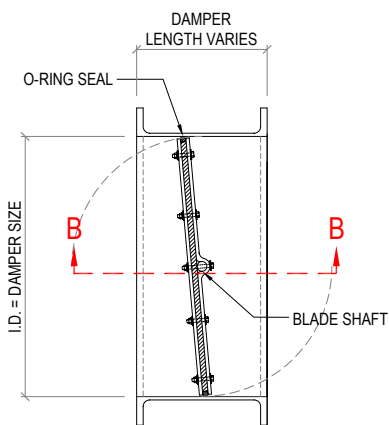

SECTION A

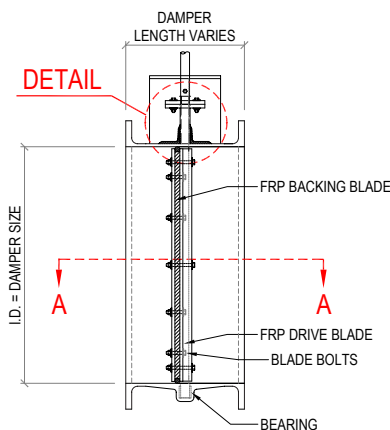

SECTION B

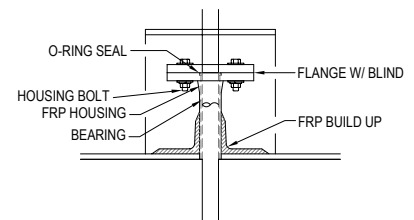

DETAIL

MODEL 504 HAS A SHAFT SEAL. MODEL 504 IS DESIGNED FOR COMPLETE ISOLATION SERVICE. EACH 504 IS TESTED WATER TIGHT.

CUSTOM CONFIGURATIONS

M.K. Plastics dampers can be furnished in a variety of custom configurations including: extended length between flanges, undrilled flanges, inline dampers, either built into a section of duct or plain-end for field joint by installers.

STANDARD CONSTRUCTION

Resin System: Fire Retardant (FR) Vinyl Ester with MEKP Cure System

Frame: FR Vinyl Ester FRP

Axle: 316 or 304 Stainless Steel

Sizes: See Table Below

Max Operating Temp.: 200°F

External Coating: Gel Coat with UV (M.K. Plastics Light Gray)

Face to Face: See Table Below

Actuator: Locking quadrant hand lever through 20" diameter, worm gear for larger than 20". Electronic, pneumatic, and chain-wheel operators are available).

Options: Dampers can be made with a variety of resins, cure systems, gasket materials, shaft materials, internal hardware, external hardware, coatings, flange patterns, actuators, and face to face lengths. Contact M.K. Plastics for other available options.

Blade: FR Vinyl Ester FRP

Bearings: Teflon

Internal Hardware: 304 or 316 SS

Max System Pressure: 30" w.g.

Connections: ASTM D 3982, Table 1 for Standard Ductwork

Gasket: EPDM

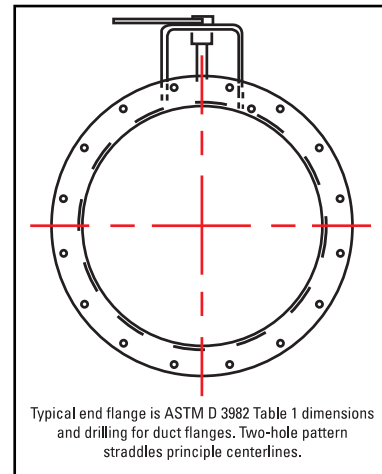

SIZES	FLANGE THICKNESS	FLANGE O.D.	BOLT CIRCLE DIA.	BOLT HOLE DIA.	# OF BOLTS	BLADE EDGE THICKNESS	AXIAL DIA.	FACE TO FACE LENGTH	*APPROX. TORQUE (In-Lb)
4"	1/2"	8-3/8"	7"	7/16"	4	5/16"	3/4"	12"	200
6"	1/2"	10-3/8"	9"	7/16"	8	5/16"	3/4"	12"	200
8"	1/2"	12-3/8"	11"	7/16"	8	5/16"	3/4"	12"	300
10"	1/2"	14-3/8"	13"	7/16"	12	5/16"	3/4"	12"	660
12"	1/2"	16-3/8"	15"	7/16"	12	3/8"	3/4"	12"	660
14"	1/2"	18-3/8"	17"	7/16"	12	3/8"	3/4"	12"	660
16"	1/2"	20-3/8"	19"	7/16"	16	3/8"	3/4"	12"	800
18"	1/2"	22-3/8"	21"	7/16"	16	3/8"	3/4"	12"	1000
20"	1/2"	24-3/8"	23"	7/16"	20	3/8"	3/4"	12"	1100
24"	1/2"	28-3/8"	27"	7/16"	20	1/2"	1-1/4"	12"	1350
26"	1/2"	30-3/8"	29"	7/16"	22	1/2"	1-1/4"	12"	1500
28"	1/2"	32-3/8"	31"	7/16"	26	1/2"	1-1/4"	12"	1650
30"	5/8"	34-3/8"	33"	7/16"	28	1/2"	1-1/4"	15"	1750
36"	5/8"	40-3/8"	39"	7/16"	32	1/2"	1-1/4"	15"	2200
40"	5/8"	44-3/8"	45"	7/16"	34	1/2"	2"	15"	2300
42"	5/8"	46-3/8"	45"	7/16"	36	5/8"	2"	15"	2500
48"	5/8"	54-3/8"	52"	9/16"	44	5/8"	2"	15"	2900
54"	5/8"	60-3/8"	58"	9/16"	44	5/8"	2"	18"	3300
60"	5/8"	66-3/8"	64"	9/16"	64	3/4"	2"	18"	3700
72"	5/8"	78-3/8"	76"	9/16"	76	3/4"	2-1/2"	24"	4500

*NOTE: Damper torque values are approximate only, and are dependent on velocity and pressure for the particular application.

CERTIFIED RATINGS AUTHORIZED BY AMCA

M.K. Plastics Corporation certifies that the Standard Model R-KD-503 & R-KD-504 Dampers shown herein are licensed to bear the AMCA Seal. The ratings shown are based on tests and procedures performed in accordance with AMCA Publication 511 and comply with the requirements of the AMCA Certified Ratings Program. The AMCA Certified Ratings Seal applies to air leakage and air performance ratings only.

1. Test method per AMCA Standard 500-89
2. Air leakage is based on operation between 50°F & 104°F

MODEL K-RD-503 ROUND DAMPERS		MODEL R-KD-504 ROUND DAMPERS	
DAMPER DIAMETER	6" - 48"	DAMPER DIAMETER	10" - 60"
AMCA LEAKAGE CLASS		AMCA LEAKAGE CLASS	
CLASS 1A 1" w.g.	CLASS 1 4" w.g., 8" w.g., 12" w.g.	CLASS 1A 1" w.g.	CLASS 1 4" w.g., 8" w.g., 12" w.g.

PRESSURE CLASS	LEAKAGE, L/s/m ² (ft ³ /min/ft ²)			
	REQUIRED RATING		EXTENDED RANGE (OPTIONAL)	
	0.25 kPa (1" w.g.)	1.0 kPa (4" w.g.)	20. kPa (8" w.g.)	3.0 kPa (12" w.g.)
1A	15.2 (3)	N/A	N/A	N/A
1	20.3 (4)	40.6 (8)	55.9 (11)	71.1 (14)
2	50.8 (10)	102 (20)	142 (28)	178 (35)
3	203 (40)	406 (80)	569 (112)	711 (140)

AIR PERFORMANCE FOR K-RD-503 & K-RD-504 DAMPERS FULL OPEN POSITION

