

FIBERGLASS BACKDRAFT DAMPER

97-02-April 2010



Model K-GD

APPLICATION & FEATURES

The M.K. Plastics series K-GD series end-pivoted fiberglass gravity backdraft dampers are intended for low to medium pressure and velocity applications where corrosive elements exist in the air stream. Recommended for backdraft control to allow airflow in one direction and prevent airflow in the opposite. Maximum temperature is 200°F. The K-GD series dampers can be flange or duct mounted in either vertical or horizontal applications. Flange drilling is available as an option.

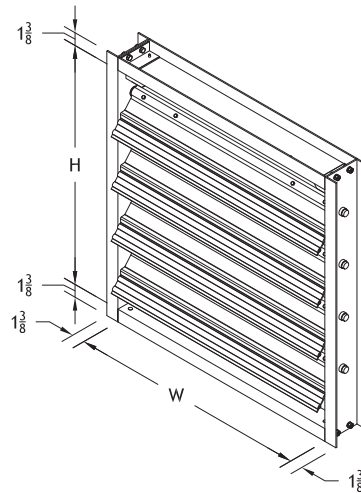

STANDARD CONSTRUCTION

FRAME

4" or 6" x 1/8" thick vinyl ester resin C-channel.

BLADE

6-1/4" wide vinyl ester resin with optional extruded silicone rubber seals.

LINKAGE

FRP tie bar, air stream mounted on the discharge side of the blade.

AXLES

5/8" dia. vinyl ester resin rod.

BEARINGS

Teflon molded thermoplastic.

HARDWARE

304 stainless steel (standard).

MINIMUM SIZE

Single blade: 6"W x 8"H.

MAXIMUM SIZE

Single section: 36"W (blade length). Larger sizes available in multiple sections.

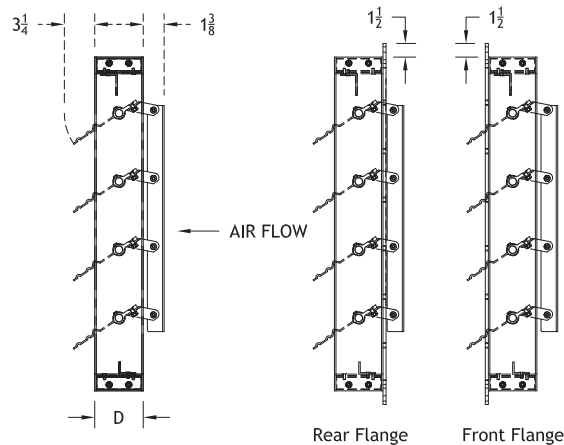

'D' dimension -
4" For W <= 25 3/4" and H <= 25 3/4"
6" For W > 25 3/4" or H >= 25 3/4"

K-GD SUGGESTED SPECIFICATION

Furnish and install FRP gravity backdraft dampers, as shown on plans or as described in the schedule as per following specifications. Dampers shall comply to ASTM D4385-84A standards and frames, blades and axles should be of pultruded construction. Resin used shall be flame retardant vinyl ester with a Class I flame spread rate of 25 or less. All surfaces are protected to be ultra-violet resistant. Frames shall be 4" wide up to 25-3/4" size and 6" wide on larger dampers, "C" channel type with 1/8" wall thickness. Damper blades shall be of 1/8" thick, 6-1/4" wide single skin, V-groove design and all blade surfaces shall use surface veils. Damper axles shall be minimum 5/8" dia. pultruded construction vinyl ester resin rods. Damper blade linkage shall consist of an FRP tie bar, air stream mounted on the inlet side of the blade with 304 stainless steel hardware. Bearings shall be Teflon molded thermoplastic, design based on system pressure. Damper shall be M.K. Plastics Corporation model K-GD or equivalent.



BLADE DESIGN PRESSURE LIMITATION

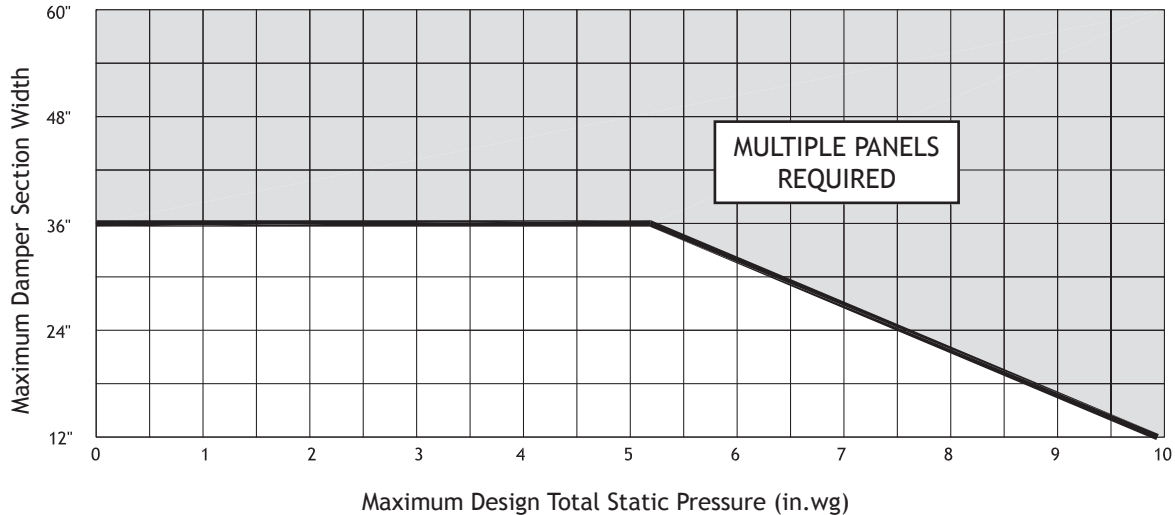

PERFORMANCE DATA

Damper Width	Minimum Velocity Blades Fully Open	Maximum System Velocity	*Leakage with Seals		*Leakage without Seals	
			% of max. flow	CFM / sq.ft	% of max. flow	CFM / sq.ft
48"	500 fpm	2,500 fpm	0.17	6	1.00	20
36"	500 fpm	2,500 fpm	0.17	6	1.50	30
24"	500 fpm	2,500 fpm	0.20	8	1.70	40
12"	500 fpm	2,500 fpm	0.25	10	2.00	60

*Leakage based on pressure differential of 1" w.g., tested per AMCA Std. 500.

LEAKAGE CORRECTION FACTOR

Static Pressure [in. w.g]	1	2	3	4	5	6	7	8	9	10	11	12	13	14	15	16
Correction Factor	1.0	1.3	1.7	1.9	2.2	2.4	2.6	2.8	3.0	3.1	3.3	3.5	3.6	3.7	3.8	4.0

DETERMINING LEAKAGE:

To determine leakage at static pressure differentials higher than one inch water gage, multiply leakage at one inch determined from appropriate table above) by correction factor for higher static pressure (determined from the Leakage Correction Factor Table).

Example:

Find leakage for a 24" wide damper with optional seals at 4 inches water gage: 8 CFM/sq. ft. x 1.9 = 15.2 CFM/sq. ft. leakage at 4 inches water gage.

FIBERGLASS BACKDRAFT DAMPER

97-02-April 2010



Model K-GD

MOUNTING CONFIGURATION

There are two types of mounting configurations available, vertical or horizontal –

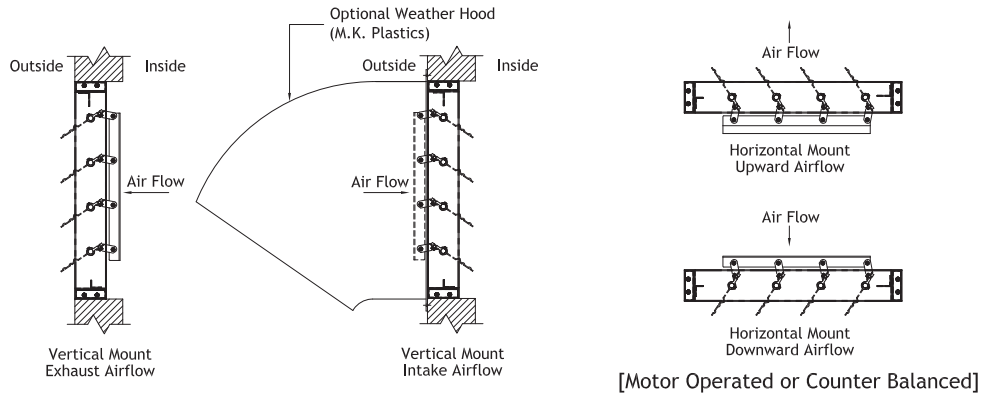

FRAME CONFIGURATION

Dampers can be straight duct/wall, rear or front flange mounted –

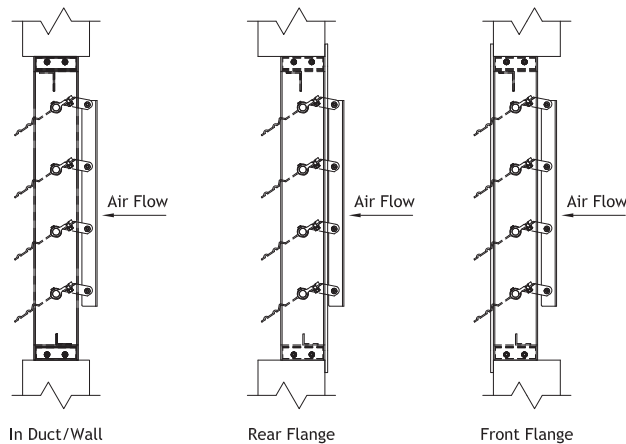

CURB MOUNTING

Dampers can be curb mounted in damper trays –

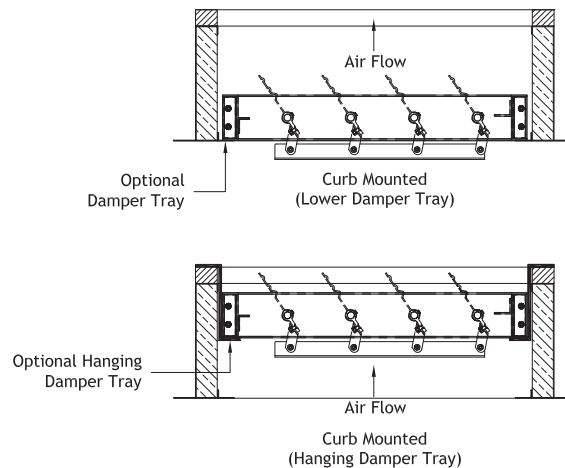

FIBERGLASS BACKDRAFT DAMPER

97-02-April 2010



Model K-GD

FAN DISCHARGE DAMPER

K-GD dampers can be used on fan outlets for automatic isolation to allow flow at discharge in one direction and prevent backdraft in the opposite direction –

DAMPER OPERATION

Dampers can either be operated by gravity, where velocity opens and closes the blades, or they can be motorized to open and close –

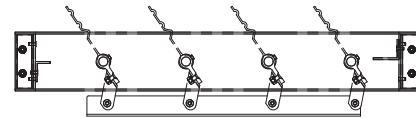
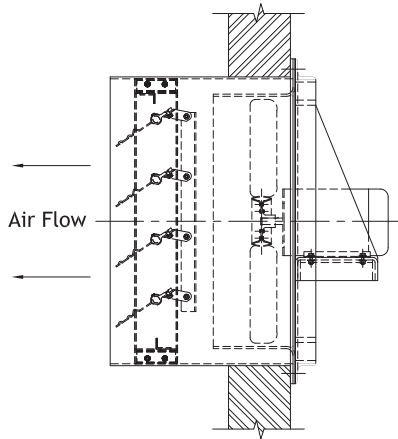

Gravity Operated

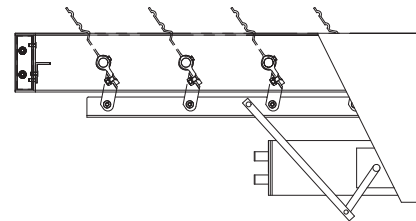

Actuator Operated

SELECTION & OPTIONS

Item No.	QTY	W	H	Frame Style			Orientation		Comments <small>*Please indicate in the horizontal position if the airflow is up-blast or down-blast. See pages 3 & 4 for mounting options</small>
				Std.	Front Flange	Rear Flange	*Horizontal	Vertical	
1.									
2.									
3.									
4.									
5.									
6.									
Project:		Contractor:				Date:			
Location:		Engineer:							

Item No.	Blade Seals	*Inlet Screen		Blade Counter Balance Weights		*Pre-Drilled Flanges	
		PVC	304 Stainless steel	To Assist Opening	To Assist Closing	Inlet	Outlet
1.							
2.							
3.							
4.							
5.							
6.							

*Consult M.K. Plastics for design, size and location of screen & flange bolt hole pattern. Certified prints are available from the factory.